

# PXI

## **NI PXI-8250 User Manual**

*National Instruments System Monitor Hardware*

## **Worldwide Technical Support and Product Information**

ni.com

### **National Instruments Corporate Headquarters**

11500 North Mopac Expressway Austin, Texas 78759-3504 USA Tel: 512 683 0100

### **Worldwide Offices**

Australia 1800 300 800, Austria 43 662 457990-0, Belgium 32 (0) 2 757 0020, Brazil 55 11 3262 3599,  
Canada 800 433 3488, China 86 21 5050 9800, Czech Republic 420 224 235 774, Denmark 45 45 76 26 00,  
Finland 358 (0) 9 725 72511, France 01 57 66 24 24, Germany 49 89 7413130, India 91 80 41190000,  
Israel 972 3 6393737, Italy 39 02 41309277, Japan 0120-527196, Korea 82 02 3451 3400,  
Lebanon 961 (0) 1 33 28 28, Malaysia 1800 887710, Mexico 01 800 010 0793, Netherlands 31 (0) 348 433 466,  
New Zealand 0800 553 322, Norway 47 (0) 66 90 76 60, Poland 48 22 3390150, Portugal 351 210 311 210,  
Russia 7 495 783 6851, Singapore 1800 226 5886, Slovenia 386 3 425 42 00, South Africa 27 0 11 805 8197,  
Spain 34 91 640 0085, Sweden 46 (0) 8 587 895 00, Switzerland 41 56 2005151, Taiwan 886 02 2377 2222,  
Thailand 662 278 6777, Turkey 90 212 279 3031, United Kingdom 44 (0) 1635 523545

For further support information, refer to the *Technical Support and Professional Services* appendix. To comment on National Instruments documentation, refer to the National Instruments Web site at [ni.com/info](http://ni.com/info) and enter the info code `feedback`.

# Important Information

---

## Warranty

The NI PXI-8250 is warranted against defects in materials and workmanship for a period of one year from the date of shipment, as evidenced by receipts or other documentation. National Instruments will, at its option, repair or replace equipment that proves to be defective during the warranty period. This warranty includes parts and labor.

The media on which you receive National Instruments software are warranted not to fail to execute programming instructions, due to defects in materials and workmanship, for a period of 90 days from date of shipment, as evidenced by receipts or other documentation. National Instruments will, at its option, repair or replace software media that do not execute programming instructions if National Instruments receives notice of such defects during the warranty period. National Instruments does not warrant that the operation of the software shall be uninterrupted or error free.

A Return Material Authorization (RMA) number must be obtained from the factory and clearly marked on the outside of the package before any equipment will be accepted for warranty work. National Instruments will pay the shipping costs of returning to the owner parts which are covered by warranty.

National Instruments believes that the information in this document is accurate. The document has been carefully reviewed for technical accuracy. In the event that technical or typographical errors exist, National Instruments reserves the right to make changes to subsequent editions of this document without prior notice to holders of this edition. The reader should consult National Instruments if errors are suspected. In no event shall National Instruments be liable for any damages arising out of or related to this document or the information contained in it.

EXCEPT AS SPECIFIED HEREIN, NATIONAL INSTRUMENTS MAKES NO WARRANTIES, EXPRESS OR IMPLIED, AND SPECIFICALLY DISCLAIMS ANY WARRANTY OF MERCHANTABILITY OR FITNESS FOR A PARTICULAR PURPOSE. CUSTOMER'S RIGHT TO RECOVER DAMAGES CAUSED BY FAULT OR NEGLIGENCE ON THE PART OF NATIONAL INSTRUMENTS SHALL BE LIMITED TO THE AMOUNT THERETOFORE PAID BY THE CUSTOMER. NATIONAL INSTRUMENTS WILL NOT BE LIABLE FOR DAMAGES RESULTING FROM LOSS OF DATA, PROFITS, USE OF PRODUCTS, OR INCIDENTAL OR CONSEQUENTIAL DAMAGES, EVEN IF ADVISED OF THE POSSIBILITY THEREOF. This limitation of the liability of National Instruments will apply regardless of the form of action, whether in contract or tort, including negligence. Any action against National Instruments must be brought within one year after the cause of action accrues. National Instruments shall not be liable for any delay in performance due to causes beyond its reasonable control. The warranty provided herein does not cover damages, defects, malfunctions, or service failures caused by owner's failure to follow the National Instruments installation, operation, or maintenance instructions; owner's modification of the product; owner's abuse, misuse, or negligent acts; and power failure or surges, fire, flood, accident, actions of third parties, or other events outside reasonable control.

## Copyright

Under the copyright laws, this publication may not be reproduced or transmitted in any form, electronic or mechanical, including photocopying, recording, storing in an information retrieval system, or translating, in whole or in part, without the prior written consent of National Instruments Corporation.

National Instruments respects the intellectual property of others, and we ask our users to do the same. NI software is protected by copyright and other intellectual property laws. Where NI software may be used to reproduce software or other materials belonging to others, you may use NI software only to reproduce materials that you may reproduce in accordance with the terms of any applicable license or other legal restriction.

## Trademarks

National Instruments, NI, ni.com, and LabVIEW are trademarks of National Instruments Corporation. Refer to the *Terms of Use* section on [ni.com/legal](http://ni.com/legal) for more information about National Instruments trademarks.

Other product and company names mentioned herein are trademarks or trade names of their respective companies.

Members of the National Instruments Alliance Partner Program are business entities independent from National Instruments and have no agency, partnership, or joint-venture relationship with National Instruments.

## Patents

For patents covering National Instruments products, refer to the appropriate location: **Help»Patents** in your software, the `patents.txt` file on your media, or [ni.com/patents](http://ni.com/patents).

## WARNING REGARDING USE OF NATIONAL INSTRUMENTS PRODUCTS

(1) NATIONAL INSTRUMENTS PRODUCTS ARE NOT DESIGNED WITH COMPONENTS AND TESTING FOR A LEVEL OF RELIABILITY SUITABLE FOR USE IN OR IN CONNECTION WITH SURGICAL IMPLANTS OR AS CRITICAL COMPONENTS IN ANY LIFE SUPPORT SYSTEMS WHOSE FAILURE TO PERFORM CAN REASONABLY BE EXPECTED TO CAUSE SIGNIFICANT INJURY TO A HUMAN.

(2) IN ANY APPLICATION, INCLUDING THE ABOVE, RELIABILITY OF OPERATION OF THE SOFTWARE PRODUCTS CAN BE IMPAIRED BY ADVERSE FACTORS, INCLUDING BUT NOT LIMITED TO FLUCTUATIONS IN ELECTRICAL POWER SUPPLY, COMPUTER HARDWARE MALFUNCTIONS, COMPUTER OPERATING SYSTEM SOFTWARE FITNESS, FITNESS OF COMPILERS AND DEVELOPMENT SOFTWARE USED TO DEVELOP AN APPLICATION, INSTALLATION ERRORS, SOFTWARE AND HARDWARE COMPATIBILITY PROBLEMS, MALFUNCTIONS OR FAILURES OF ELECTRONIC MONITORING OR CONTROL DEVICES, TRANSIENT FAILURES OF ELECTRONIC SYSTEMS (HARDWARE AND/OR SOFTWARE), UNANTICIPATED USES OR MISUSES, OR ERRORS ON THE PART OF THE USER OR APPLICATIONS DESIGNER (ADVERSE FACTORS SUCH AS THESE ARE HEREAFTER COLLECTIVELY TERMED "SYSTEM FAILURES"). ANY APPLICATION WHERE A SYSTEM FAILURE WOULD CREATE A RISK OF HARM TO PROPERTY OR PERSONS (INCLUDING THE RISK OF BODILY INJURY AND DEATH) SHOULD NOT BE RELIANT SOLELY UPON ONE FORM OF ELECTRONIC SYSTEM DUE TO THE RISK OF SYSTEM FAILURE. TO AVOID DAMAGE, INJURY, OR DEATH, THE USER OR APPLICATION DESIGNER MUST TAKE REASONABLY PRUDENT STEPS TO PROTECT AGAINST SYSTEM FAILURES, INCLUDING BUT NOT LIMITED TO BACK-UP OR SHUT DOWN MECHANISMS, BECAUSE EACH END-USER SYSTEM IS CUSTOMIZED AND DIFFERS FROM NATIONAL INSTRUMENTS' TESTING PLATFORMS AND BECAUSE A USER OR APPLICATION DESIGNER MAY USE NATIONAL INSTRUMENTS PRODUCTS IN COMBINATION WITH OTHER PRODUCTS IN A MANNER NOT EVALUATED OR CONTEMPLATED BY NATIONAL INSTRUMENTS, THE USER OR APPLICATION DESIGNER IS ULTIMATELY RESPONSIBLE FOR VERIFYING AND VALIDATING THE SUITABILITY OF NATIONAL INSTRUMENTS PRODUCTS WHENEVER NATIONAL INSTRUMENTS PRODUCTS ARE INCORPORATED IN A SYSTEM OR APPLICATION, INCLUDING, WITHOUT LIMITATION, THE APPROPRIATE DESIGN, PROCESS AND SAFETY LEVEL OF SUCH SYSTEM OR APPLICATION.

# Contents

---

## About This Manual

Conventions .....	vii
Related Documentation.....	viii

## Chapter 1 Getting Started

About the NI PXI-8250 Module .....	1-1
Features.....	1-1
What You Need to Get Started .....	1-2
Software Programming Choices .....	1-2
Safety Information .....	1-2

## Chapter 2 Configuration and Installation

Software Installation .....	2-1
Hardware Installation.....	2-1
NI PXI-8250 Configuration .....	2-5

## Chapter 3 Hardware Overview

System Monitoring Architecture .....	3-3
Voltage Rail Level Monitoring .....	3-3
Temperature Monitoring .....	3-3
Fan Monitoring.....	3-4
Additional Monitoring Features .....	3-4
Front Panel LEDs.....	3-4
System Status LEDs .....	3-5
User LEDs .....	3-5
Front Panel Connector .....	3-5
Alert Relay Pins.....	3-7
Power Output Pins.....	3-7

## Appendix A Specifications

**Appendix B**  
**Technical Support and Professional Services**

**Glossary**

**Index**

# About This Manual

---

The *NI PXI-8250 User Manual* describes the features of the NI PXI-8250, and contains information about configuring and operating the hardware.

## Conventions

---

The following conventions are used in this manual:

»

The » symbol leads you through nested menu items and dialog box options to a final action. The sequence **File»Page Setup»Options** directs you to pull down the **File** menu, select the **Page Setup** item, and select **Options** from the last dialog box.



This icon denotes a note, which alerts you to important information.



This icon denotes a caution, which advises you of precautions to take to avoid injury, data loss, system crash, product damage, or product malfunction. When this symbol is marked on the product, refer to the *Read Me First: Safety and Radio-Frequency Interference* document, shipped with the product, for precautions to take.

**bold**

Bold text denotes items that you must select or click in the software, such as menu items and dialog box options. Bold text also denotes parameter names.

*italic*

Italic text denotes variables, emphasis, a cross-reference, or an introduction to a key concept. Italic text also denotes text that is a placeholder for a word or value that you must supply.

monospace

Text in this font denotes text or characters that you should enter from the keyboard, sections of code, programming examples, and syntax examples. This font is also used for the proper names of disk drives, paths, directories, programs, subprograms, subroutines, device names, functions, operations, variables, filenames, and extensions.

NI PXI-1042/1042Q

NI PXI-1042/1042Q indicates that either an NI PXI-1042 or NI PXI-1042Q chassis may be used. When the NI PXI-1042Q chassis is referred to alone in the text, then the text is not relevant to the NI PXI-1042 chassis.

## Related Documentation

---

The following documents contain information that you might find helpful as you read this manual:

- IEEE 1101.1-1991, *IEEE Standard for Mechanical Core Specifications for Microcomputers Using IEC 603-2 Connectors*
- IEEE 1101.10, *IEEE Standard for Additional Mechanical Specifications for Microcomputers Using IEEE 1101.1 Equipment Practice*
- *PICMG EXP.0 R1.0 CompactPCI Express Specification*, PCI Industrial Computers Manufacturers Group
- *PCI Express Base Specification*, Revision 1.1, PCI Special Interest Group
- *PXI-5 PXI Express Hardware Specification*, Revision 1.0, PXI Systems Alliance
- *NI System Monitor 1.1 Help*

---

# Getting Started

This chapter includes information about the features of the NI PXI-8250 and information about operating the hardware.

## About the NI PXI-8250 Module

---

The NI PXI-8250 module monitors the status parameters of a chassis and displays the status information with front panel LEDs and an alert relay.

### Features

NI PXI-8250 can be used with an NI PXI-1042, NI PXI-1042Q, or NI PXI-1045 chassis to detect and report chassis voltage rail problems, out-of-range chassis intake temperature, or chassis power shuttle fan failure. The NI PXI-8250 monitors the status of these parameters and reports the status through a set of LEDs on the front panel of the module. The NI PXI-8250 also includes a relay that toggles when any of the parameters fall outside of specification during chassis operation. These features can be used to monitor the state of the chassis and easily identify system failure.

The NI PXI-8250 comes with *NI System Monitor* software that includes the driver for the module and an application programming interface (API) that allows programmatic access to the information reported by the module. Although the driver allows for proper detection of the hardware, it is not required for the normal operation of the six system status LEDs, the alert relay, or the power outputs of the NI PXI-8250.

There is also a set of six user LEDs on the front panel of the NI PXI-8250 designed for custom alert configurations. This feature is not available with *NI System Monitor 1.1*, and may be added in future releases of *NI System Monitor*. Refer to the *NI System Monitor Help* for more information.



## What You Need to Get Started

---

To set up and use the NI PXI-8250 module, you must have the following items:

- An NI PXI-8250 System Monitor module
- An NI PXI-1042, NI PXI-1042Q, or NI PXI-1045 chassis
- This manual
- Optional: The *NI System Monitor 1.1* driver software and documentation

## Software Programming Choices

---

The *NI System Monitor* software includes a simple but powerful high-level application programming interface (API) that makes creating custom applications for the NI PXI-8250 easy. Refer to the *NI System Monitor 1.1 Help* for information on the API.

## Safety Information

---



**Caution** The following paragraphs contain important safety information you must follow when installing and operating the NI PXI-8250, and all devices connecting to the NI PXI-8250.

Do not operate the device in a manner not specified in this document. Misuse of the device can result in a hazard. You can compromise the safety protection built into the device if the device is damaged in any way. If the device is damaged, return it to National Instruments (NI) for repair.

Do not substitute parts or modify the device except as described in this document. Use the device only with the chassis, specified in the installation instructions. You must have all covers and filler panels installed during operation of the device.

Do not operate the device in an explosive atmosphere or where there may be flammable gases or fumes. If you must operate the device in such an environment, it must be in a suitably rated enclosure.

If you need to clean the device, use a soft, nonmetallic brush. Make sure that the device is completely dry and free from contaminants before returning it to service.

Operate the device only at or below Pollution Degree 2. Pollution is foreign matter in a solid, liquid, or gaseous state that can reduce dielectric strength or surface resistivity. The following is a description of pollution degrees:

- Pollution Degree 1 means no pollution or only dry, nonconductive pollution occurs. The pollution has no influence.
- Pollution Degree 2 means that only nonconductive pollution occurs in most cases. Occasionally, however, a temporary conductivity caused by condensation must be expected.
- Pollution Degree 3 means that conductive pollution occurs, or dry, nonconductive pollution occurs that becomes conductive due to condensation.



**Note** The NI PXI-8250 is intended for indoor use only.

You must insulate signal connections for the maximum voltage for which the device is rated. Do not exceed the maximum ratings for the device. Do not install wiring while the device is live with electrical signals. Do not remove or add connector blocks when power is connected to the system. Remove power from signal lines before connecting them to or disconnecting them from the device.

Operate the device at or below the *installation category*<sup>1</sup> marked on the hardware label. Measurement circuits are subjected to *working voltages*<sup>2</sup> and transient stresses (overvoltage) from the circuit to which they are connected during measurement or test. Installation categories establish standard impulse withstand voltage levels that commonly occur in electrical distribution systems. The following is a description of installation categories:

- Installation Category I is for measurements performed on circuits not directly connected to the electrical distribution system referred to as *MAINS*<sup>3</sup> voltage. This category is for measurements of voltages from specially protected secondary circuits. Such voltage measurements include signal levels, special equipment, limited-energy parts of

---

<sup>1</sup> Installation categories, also referred to as measurement categories, are defined in electrical safety standard IEC 61010-1.

<sup>2</sup> Working voltage is the highest rms value of an AC or DC voltage that can occur across any particular insulation.

<sup>3</sup> MAINS is defined as a hazardous live electrical supply system that powers equipment. Suitably rated measuring circuits may be connected to the MAINS for measuring purposes.

equipment, circuits powered by regulated low-voltage sources, and electronics.

- Installation Category II is for measurements performed on circuits directly connected to the electrical distribution system. This category refers to local-level electrical distribution, such as that provided by a standard wall outlet (for example, 115 AC voltage for U.S. or 230 AC voltage for Europe). Examples of Installation Category II are measurements performed on household appliances, portable tools, and similar devices/modules.
- Installation Category III is for measurements performed in the building installation at the distribution level. This category refers to measurements on hard-wired equipment such as equipment in fixed installations, distribution boards, and circuit breakers. Other examples are wiring, including cables, bus bars, junction boxes, switches, socket outlets in the fixed installation, and stationary motors with permanent connections to fixed installations.
- Installation Category IV is for measurements performed at the primary electrical supply installation (<1,000 V). Examples include electricity meters and measurements on primary overcurrent protection devices and on ripple control units.

---

# Configuration and Installation

This chapter describes how to configure and install the NI PXI-8250.

## Software Installation

---

Before installing the NI PXI-8250, install the *NI System Monitor* driver software. Refer to the *NI System Monitor 1.1 Help* for specific installation instructions.



**Notes** It is necessary to install the *NI System Monitor* driver software before attempting to use the NI PXI-8250, or the system will not recognize the NI PXI-8250 and you will be unable to configure or use the device.

The NI PXI-8250 will not be visible in Measurement & Automation Explorer (MAX) even after proper installation. You can see the module in Windows Device Manager once the installation process is complete and Device Manager has been refreshed.

When adding or removing an NI PXI-8250 module from a Windows XP/2000/NT system, you must be logged on with administrator-level permission. The NI PXI-8250 will not be viewable in Measurement & Automation Explorer (MAX) at any time.

## Hardware Installation

---

The following instructions are for general module installation in the specified chassis. Consult the PXI chassis user manual for a given chassis for chassis-specific instructions and warnings related to installation or module configuration.



**Cautions** The NI PXI-8250 module may sustain damage or inflict damage on adjacent modules if improperly installed.

Proper slot selection is required for the operation of this module. If the module is installed in any other slot, the module will not operate and could potentially cause other adjacent modules to not operate. Appendix A, *Specifications*, lists the typical power required for the NI PXI-8250 module.

The NI PXI-8250 is a sensitive electronic device shipped in an antistatic bag. Open only at an approved workstation and observe precautions for handling electrostatic-sensitive devices.



**Note** Install the NI PXI-8250 in only the right-most slot of an NI PXI-1042/1042Q or NI PXI-1045. As such, the NI PXI-8250 should only be installed in slot 8 of an NI PXI-1042/1042Q chassis or slot 18 of an NI PXI-1045 chassis.

Complete the following steps to install the NI PXI-8250 module.

1. Power off and unplug the chassis.



**Caution** To protect yourself and the computer from electrical hazards, the chassis must remain unplugged until the installation is complete.

2. Locate the rightmost (last numbered) slot of the NI PXI-1042/1042Q or NI PXI-1045 chassis and ensure it is unused. If occupied, relocate the module or remove the filler panel. Refer to Figure 2-1 for the location of this slot on the NI PXI-1042/1042Q chassis, and Figure 2-2 for the location of this slot on the NI PXI-1045 chassis.

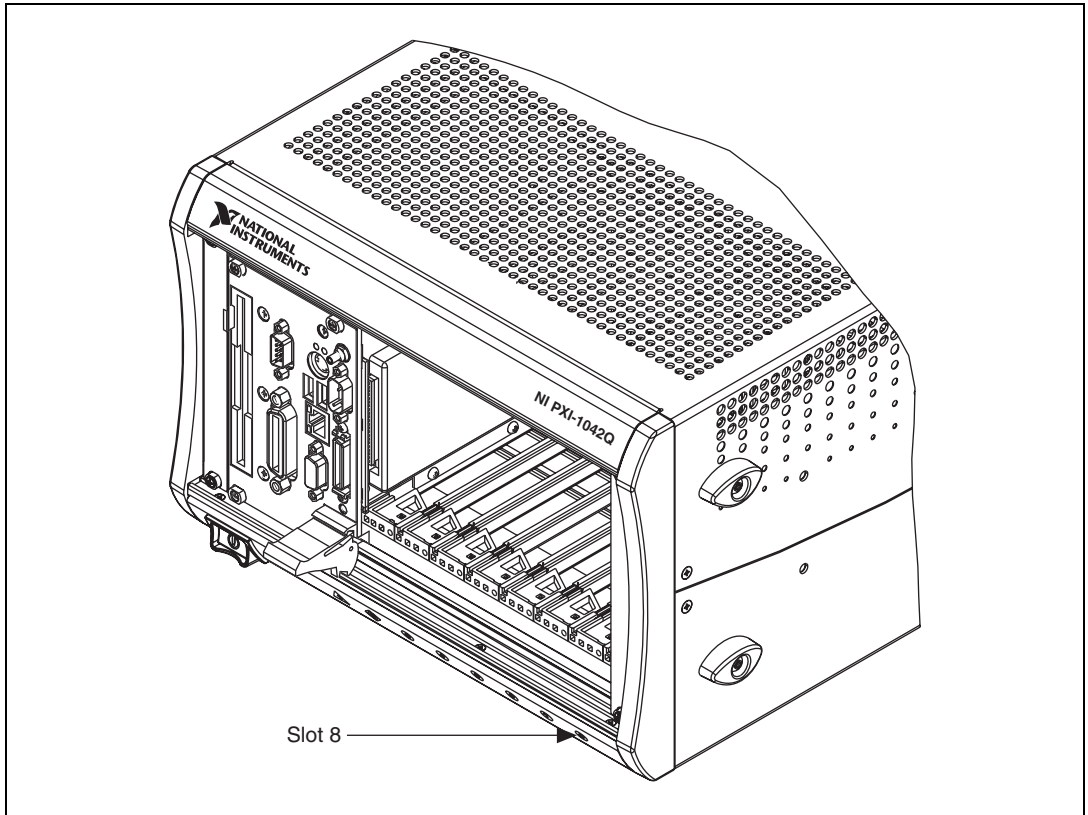

**Figure 2-1.** Location of NI PXI-1042Q Slot for NI PXI-8250 Support

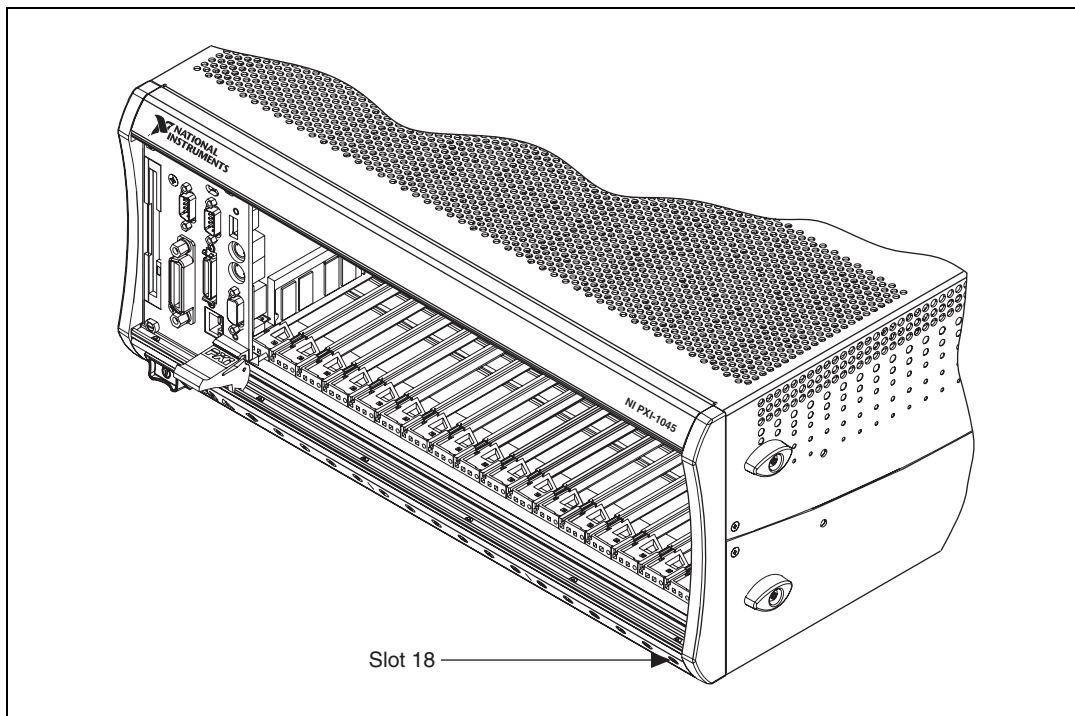

**Figure 2-2.** Location of NI PXI-1045 Slot for NI PXI-8250 Support

3. Touch a metal part on the chassis to discharge any static electricity that might be on your clothes or body. Static electricity can damage the hardware.
4. Insert the NI PXI-8250 module into the rightmost slot of an NI PXI-1042/1042Q or NI PXI-1045. The correct position is slot 8 for the NI PXI-1042/1042Q and slot 18 for the NI PXI-1045, as shown in Figure 2-1 and Figure 2-2, respectively. Use the injector/ejector handle to fully inject the device into place.
5. Screw the front panel of the NI PXI-8250 to the front panel mounting rails of the chassis.
6. Install a system controller or verify that a system controller has been installed in the controller slot.
7. Plug in and power on the chassis.
8. Plug in and power on the host computer if using a remote controller in the chassis.

9. Allow the operating system to properly detect and identify the NI PXI-8250 module.
10. Launch Windows Device Manager and refresh the view.

The NI PXI-8250 module should be visible in Windows Device Manager.

## NI PXI-8250 Configuration

---

The NI PXI-8250 module is fully compatible with the industry standard *PXI Specification, Revision 2.2*, and the *PCI Local Bus Specification, Revision 3.0*, respectively. This compatibility allows the PXI system to automatically perform all bus-related configuration and requires no user interaction. Since the NI PXI-8250 does not require configuration, it will not show up in MAX.



# Hardware Overview

This chapter presents an overview of the NI PXI-8250 functionality.

Figure 3-1, Figure 3-2, and Figure 3-3 show the locations of key features for the NI PXI-8250 module.

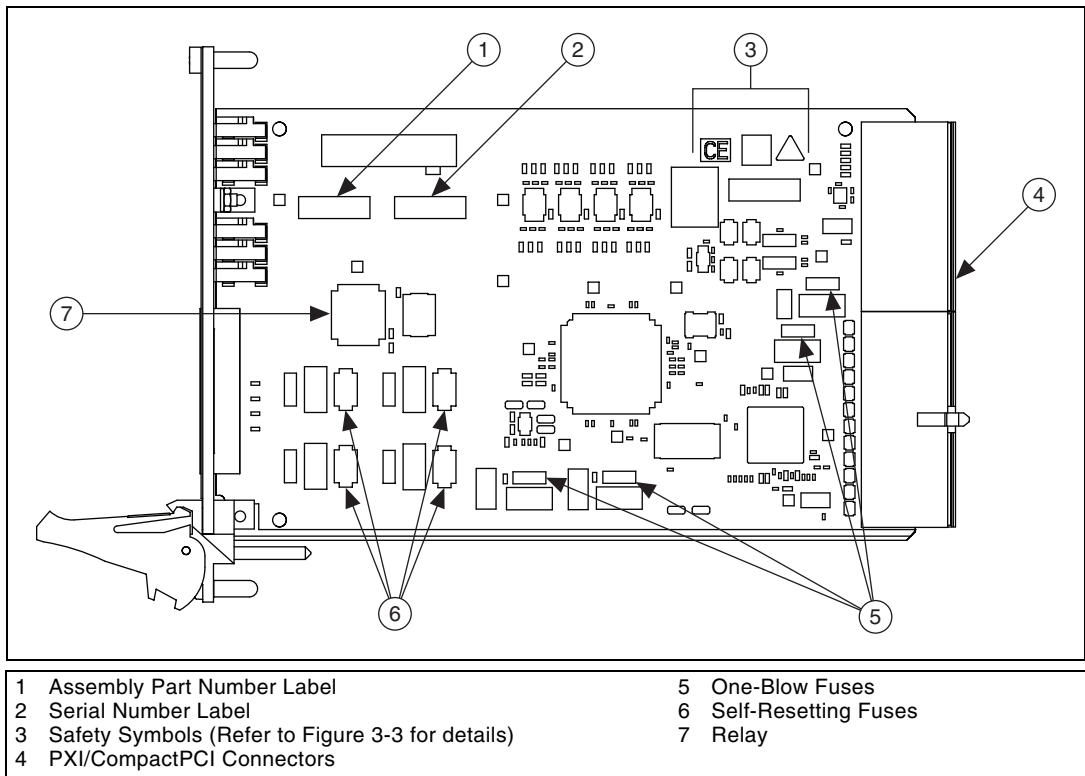

**Figure 3-1.** NI PXI-8250 Parts Locator Diagram

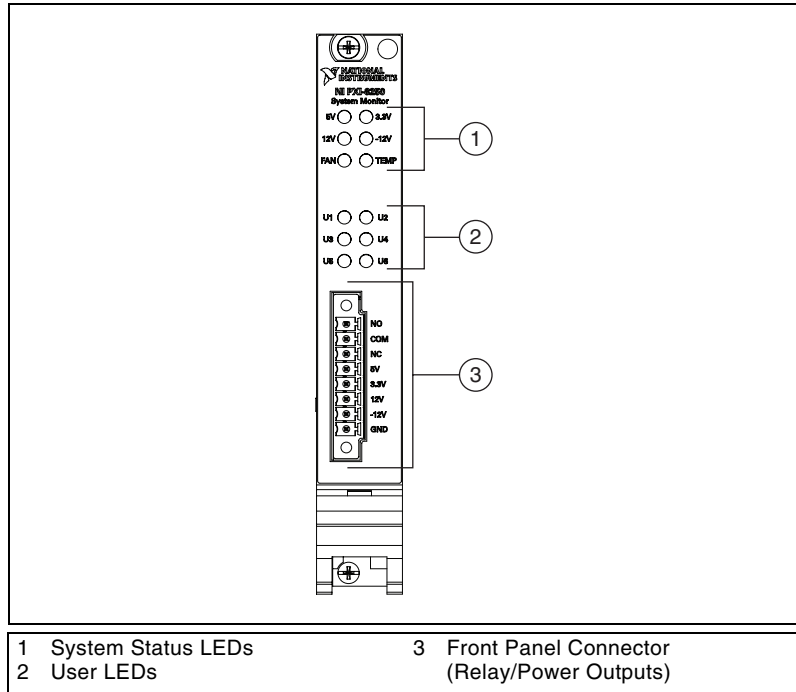

**Figure 3-2.** NI PXI-8250 Front Panel Diagram

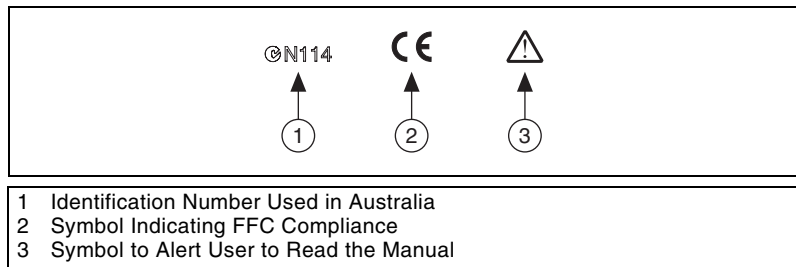

**Figure 3-3.** Symbols on the Back of the NI PXI-8250

# System Monitoring Architecture

---

With the NI PXI-8250, you can simultaneously monitor intake temperature, fan speeds, and power supply levels of your NI PXI chassis. This information allows the user to achieve a higher level of system performance reliability. Once the first set of data is processed, these status parameters will also light up the top six LEDs on the front panel. The LEDs light either as green if the status parameter is in range, or red if the parameter is out of range. Refer to the [Front Panel LEDs](#) section for more information on the LEDs.

A custom FPGA on the NI PXI-8250 communicates with the power supply module of the chassis for status information. Upon boot-up, the NI PXI-8250 waits 7 seconds for the chassis sensors to acquire their first value. Once the wait period is over, the NI PXI-8250 begins acquisition of the first full set of data from the chassis. The status information is then obtained every 5 seconds automatically in hardware until the controller is rebooted or shutdown.

## Voltage Rail Level Monitoring

The NI PXI-8250 module monitors the +5 V, +3.3 V, +12 V, and -12 V rails delivered by the power supply shuttle within an accuracy of  $\pm 100$  mV. The data from the +5 V and +3.3 V rails have two significant figures, while the data from the +12 V and -12 V rails have one significant figure.

Each power rail has its own status LED on the front panel to reflect the current status of the rail. If the voltage rail is within  $\pm 5\%$  of the common chassis specification, then the LED will light green. Otherwise, the LED will light red.

The voltage rail level monitoring feature of the NI PXI-8250 reports when a voltage rail goes out of spec. This information is useful in ensuring proper operating conditions for each PXI module.

## Temperature Monitoring

The NI PXI-8250 provides monitoring of the single intake thermistor located in the power supply shuttle of the PXI chassis. The reading from the thermistor (0–50 °C) is compared to the operating range of the chassis. If the reading is in range, the TEMP LED will light green. Otherwise, it will light red. All temperature measurements are reported in Celsius and are accurate to within 1 °C of the actual intake temperature.

## Fan Monitoring

The NI PXI-8250 module allows the user to monitor the revolutions per minute (RPM) of all rear-facing fans of a PXI chassis (two fans in an NI PXI-1042/1042Q and three fans in an NI PXI-1045), accurate to  $\pm 50$  RPM. The fan data from the chassis is interpreted by the NI PXI-8250 and the FAN front panel LED reflects the status of all of the fans collectively together. Hence, if one or more of the fans becomes non-operational (status below 1500 RPM) the LED will turn red to indicate a fan error. Otherwise, the fan LED will light green if all of the fans are operating within normal tolerances.

## Additional Monitoring Features

In addition to the system status monitoring features, the NI PXI-8250 module includes an alert relay and fused power outputs. These features are useful for user-defined monitoring applications. Refer to the [Front Panel Connector](#) section for more information on the fused power outputs.

## Front Panel LEDs

The NI PXI-8250 has 12 front panel LEDs, including 6 system status LEDs and 6 user-configured LEDs, as shown in Figure 3-4. Upon boot, all 12 LEDs will flash orange while it is being configured. The module then turns the LEDs off for 7 seconds until the first valid sample set is acquired.

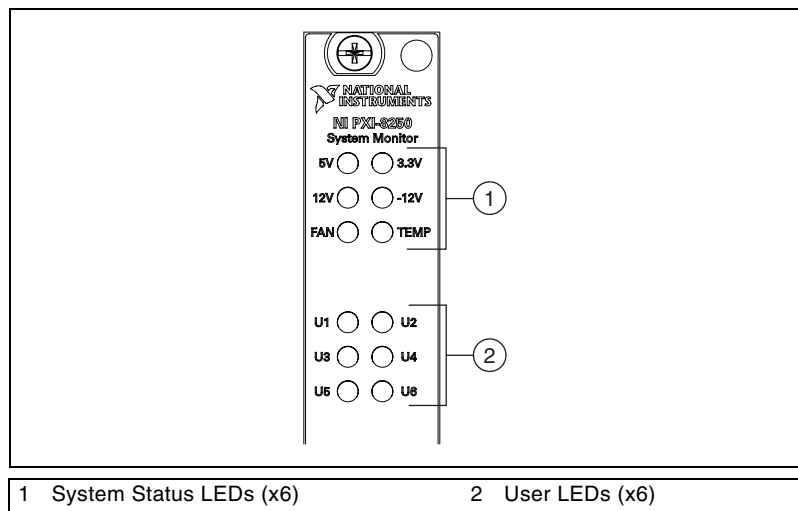

**Figure 3-4.** NI PXI-8250 Front Panel LED Diagram

## System Status LEDs

There are 6 system status LEDs to report the status of the +5 V, +3.3 V, +12 V, and -12 V power rails, the intake temperature of the chassis, and the overall status of the power shuttle fans of the chassis. These LEDs only light up either red or green depending on whether the status information shows the parameters in the specified range. The criteria for the system status LEDs to light green is provided in Table 3-1. The acceptable range for voltage rail data is  $\pm 5\%$ , 0–50 °C for the intake temperature reading, and 1500+ RPM for fan speed. Any data acquired outside of these ranges will be reflected as a red-lit LED.

**Table 3-1.** System Status LED Green State Criteria

Parameter	Criteria for Green LED status
+5 V rail	$\pm 5\%$ from nominal
+3.3 V rail	$\pm 5\%$ from nominal
+12 V rail	$\pm 5\%$ from nominal
-12 V rail	$\pm 5\%$ from nominal
Fans	>1500 RPM for all fans
Temperature	0–50 °C

## User LEDs

The 6 user LEDs are driven by implementing them in software. Refer to the *NI System Monitor 1.1 Help* for more information on developing applications for the NI PXI-8250.

## Front Panel Connector

The NI PXI-8250 has one 8-pin connector on the lower section of the front panel. The 8-pin connector provides the three connections for the relay, as well as five connections for the fused power outputs. The three relay pins included normally closed (NC), normally open (NO), and common (COM) ports to the electromechanical relay. The five power output connections include fused pins to +5V, +3.3V, +12V, -12V, and ground.



**Caution** Power off all devices before connecting or disconnecting the NI PXI-8250 plug. Failure to do so may damage the module.

Figure 3-5 shows the layout of this connector.

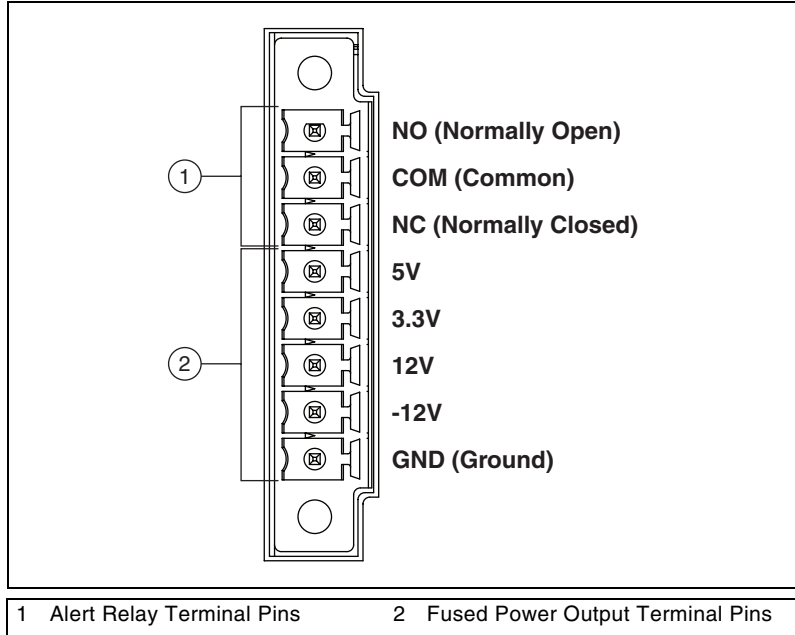

Figure 3-5. NI PXI-8250 Front Panel Connector Pinout Diagram

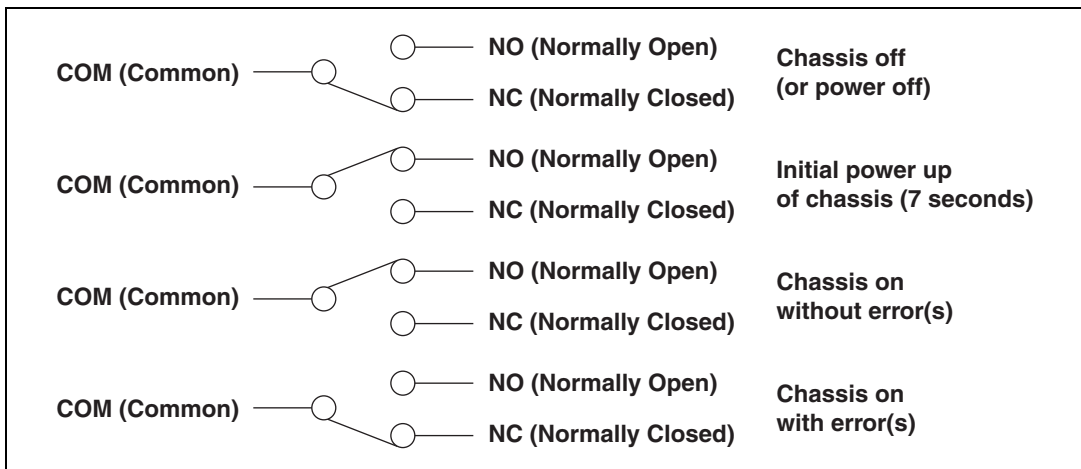

Figure 3-6. NI PXI-8250 Relay Operation Diagram

## Alert Relay Pins

The NI PXI-8250 has an electromechanical non-latching relay with three ports: normally open (NO), normally closed (NC), and common (COM). The top three pins of the front panel connector are connected to a relay as indicated in Figure 3-5. This relay is useful for a creating a custom external warning indicator circuit, such as a factory warning light or speaker.

During normal operation without any system status errors, the relay will have COM connected to NO (and not NC). Once a system status error has occurred (for instance, if the voltage rail level is out of range), the relay will flip to connect COM to NC, rather than NO. Refer to Figure 3-6 for other relay status information.



**Notes** For a use case where a warning light or speaker should be active (connected) to show an error, connect from the COM to the NC port.

For a use case where a warning light or speaker should be active (connected) to show proper, in-spec operation, connect from the COM to the NO port.

The relay alerts an error by connecting COM to NC when the chassis is powered off or loses power. The relay on the NI PXI-8250 is rated to 30 V and 1 A switching/carry current. Any connections to the relay on the NI PXI-8250 must have a wire length less than 20 meters.

## Power Output Pins

The lower 5 pins of the 8-pin front panel connector are general purpose power outputs connected to each voltage rail of the power supply. Refer to Figure 3-5 for the location of the power output pins. The +5 V, +3.3 V, +12 V, and -12 V rails are all available from these connector pins along with a ground connection at the bottom. These pins draw power from the chassis power supply and are protected from current over-draw with self-resetting fuses. Table 3-2 lists the maximum power output ratings for each voltage rail.

**Table 3-2.** Fused Power Output Ratings

Voltage Rail	Maximum Allowed Current Draw
+5.0 V	0.75 A
+3.3 V	0.75 A
+12.0 V	0.25 A
-12.0 V	0.25 A

The NI PXI-8250 has self-resetting fuses rated at 1 A/125 V on the front end and one-blow fuses rated at 4 A/125 V on the back end of the card to protect the card from excessive current draw. Refer to Figure 3-1 for the locations of these fuses.

When current is exceeded on any of the rails (the current limits are provided in Table 3-2), the self-resetting fuses will open the circuit. These fuses are designed to reset themselves and do not need to be repaired.

As a fail-safe, one blow fuses have also been added to ensure that excessive current is stopped if a self-resetting fuse fails to operate properly. In the event that any of the one-blow fuses blow, the board must be returned for repair.



---

## Specifications

This appendix lists the hardware and software performance specifications for the PXI-8250. Hardware specifications are typical at 25 °C, unless otherwise stated.



**Caution** Specifications are subject to change without notice.

### Maximum Power Requirements

Without power outputs

+5 V ( $\pm 5\%$ ) .....	0.10 A
+3.3 V ( $\pm 5\%$ ) .....	0.50 A
+12 V ( $\pm 5\%$ ) .....	0 A
-12 V ( $\pm 5\%$ ) .....	0 A
Power consumption.....	2.15 W

With power outputs

+5 V ( $\pm 5\%$ ) .....	0.85 A
+3.3 V ( $\pm 5\%$ ) .....	1.25 A
+12 V ( $\pm 5\%$ ) .....	0.25 A
-12 V ( $\pm 5\%$ ) .....	0.25 A
Power consumption.....	14.38 W

### Maximum Current for Fused Power Output

+5V rail .....	0.75 A
+3.3V rail .....	0.75 A
+12V rail .....	0.25 A
-12V rail .....	0.25 A

## Monitoring Alert Limits (Green Status LEDs)

Voltage rail level .....	±5% (from nominal)
Intake temperature .....	0–50 °C
Fan speed .....	1,500 RPM or more for all fans in a chassis

## Monitoring Accuracy

Voltage rail level readings .....	±100 mV
Intake temperature readings.....	±1 °C
Fan speed readings.....	±50 RPM

## Alert Relay Specification

Max current (switching/carry) .....	1 A
Max voltage .....	30 V
Max power .....	30 W
Max cable length .....	20 m

## Connectors

Front panel connector .....	8-pin 3.5 mm pitch, screw-flange connector
-----------------------------	---

## Physical

Front panel dimensions.....	3U × 4 HP
Overall dimensions .....	13.34 × 2.03 cm (5.25 × 0.8 in.)
Weight .....	150 g (5.29 oz)

## Environment

Maximum altitude.....	2,000 m (800 mbar) (at 25 °C ambient temperature)
Pollution Degree .....	2
Indoor use only.	

## Operating Environment

Ambient temperature range.....	0 to 55 °C (Tested in accordance with IEC-60068-2-1 and IEC-60068-2-2. Meets MIL-PRF-28800F Class 3 low temperature limit and MIL-PRF-28800F Class 2 high temperature limit.)
Relative humidity range .....	10% to 90%, noncondensing (Tested in accordance with IEC-60068-2-56.)

## Storage Environment

Ambient temperature range.....	-40 to 70 °C (Tested in accordance with IEC-60068-2-1 and IEC-60068-2-2. Meets MIL-PRF-28800F Class 3 limits.)
Relative humidity range .....	5% to 95% noncondensing (Tested in accordance with IEC-60068-2-56.)

## Shock and Vibration

Operating shock .....	30 g peak, half-sine, 11 ms pulse (Tested in accordance with IEC-60068-2-27. Meets MIL-PRF-28800F Class 2 limits.)
Random vibration operating.....	5 to 500 Hz, 0.3 g <sub>rms</sub>
Non-operating .....	5 to 500 Hz, 2.4 g <sub>rms</sub> (Tested in accordance with IEC-60068-2-64. Nonoperating test profile exceeds the requirements of MIL-PRF-28800F, Class 3.)

## Safety

This product meets the requirements of the following standards of safety for electrical equipment for measurement, control, and laboratory use:

- IEC 61010-1, EN 61010-1
- UL 61010-1, CSA 61010-1



**Note** For UL and other safety certifications, refer to the product label or the *Online Product Certification* section.

## Electromagnetic Compatibility

This product meets the requirements of the following EMC standards for electrical equipment for measurement, control, and laboratory use:

- EN 61326 (IEC 61326): Class A emissions; Basic immunity
- EN 55011 (CISPR 11): Group 1, Class A emissions
- AS/NZS CISPR 11: Group 1, Class A emissions
- FCC 47 CFR Part 15B: Class A emissions
- ICES-001: Class A emissions



**Note** For the standards applied to assess the EMC of this product, refer to the *Online Product Certification* section.



**Note** For EMC compliance, operate this product according to the documentation.

## CE Compliance

This product meets the essential requirements of applicable European Directives as follows:

- 2006/95/EC; Low-Voltage Directive (safety)
- 2004/108/EC; Electromagnetic Compatibility Directive (EMC)

## Online Product Certification

Refer to the product Declaration of Conformity (DoC) for additional regulatory compliance information. To obtain product certifications and the DoC for this product, visit [ni.com/certification](http://ni.com/certification), search by model number or product line, and click the appropriate link in the Certification column.

## Environmental Management

NI is committed to designing and manufacturing products in an environmentally responsible manner. NI recognizes that eliminating certain hazardous substances from our products is beneficial to the environment and to NI customers.

For additional environmental information, refer to the *NI and the Environment* Web page at [ni.com/environment](http://ni.com/environment). This page contains the environmental regulations and directives with which NI complies, as well as other environmental information not included in this document.

## Waste Electrical and Electronic Equipment (WEEE)



**EU Customers** At the end of the life cycle, all products *must* be sent to a WEEE recycling center. For more information about WEEE recycling centers and National Instruments WEEE initiatives, visit [ni.com/environment/weee](http://ni.com/environment/weee).

## 电子信息产品污染控制管理办法（中国 RoHS）



**中国客户** National Instruments 符合中国电子信息产品中限制使用某些有害物质指令 (RoHS)。关于 National Instruments 中国 RoHS 合规性信息，请登录 [ni.com/environment/rohs\\_china](http://ni.com/environment/rohs_china)。(For information about China RoHS compliance, go to [ni.com/environment/rohs\\_china](http://ni.com/environment/rohs_china).)

---

# Technical Support and Professional Services

Visit the following sections of the award-winning National Instruments Web site at [ni.com](http://ni.com) for technical support and professional services:

- **Support**—Technical support resources at [ni.com/support](http://ni.com/support) include the following:
  - **Self-Help Technical Resources**—For answers and solutions, visit [ni.com/support](http://ni.com/support) for software drivers and updates, a searchable KnowledgeBase, product manuals, step-by-step troubleshooting wizards, thousands of example programs, tutorials, application notes, instrument drivers, and so on. Registered users also receive access to the NI Discussion Forums at [ni.com/forums](http://ni.com/forums). NI Applications Engineers make sure every question submitted online receives an answer.
  - **Standard Service Program Membership**—This program entitles members to direct access to NI Applications Engineers via phone and email for one-to-one technical support as well as exclusive access to on demand training modules via the Services Resource Center. NI offers complementary membership for a full year after purchase, after which you may renew to continue your benefits.

For information about other technical support options in your area, visit [ni.com/services](http://ni.com/services), or contact your local office at [ni.com/contact](http://ni.com/contact).
- **Training and Certification**—Visit [ni.com/training](http://ni.com/training) for self-paced training, eLearning virtual classrooms, interactive CDs, and Certification program information. You also can register for instructor-led, hands-on courses at locations around the world.
- **System Integration**—If you have time constraints, limited in-house technical resources, or other project challenges, National Instruments Alliance Partner members can help. To learn more, call your local NI office or visit [ni.com/alliance](http://ni.com/alliance).

- **Declaration of Conformity (DoC)**—A DoC is our claim of compliance with the Council of the European Communities using the manufacturer’s declaration of conformity. This system affords the user protection for electromagnetic compatibility (EMC) and product safety. You can obtain the DoC for your product by visiting [ni.com/certification](http://ni.com/certification).
- **Calibration Certificate**—If your product supports calibration, you can obtain the calibration certificate for your product at [ni.com/calibration](http://ni.com/calibration).

If you searched [ni.com](http://ni.com) and could not find the answers you need, contact your local office or NI corporate headquarters. Phone numbers for our worldwide offices are listed at the front of this manual. You also can visit the Worldwide Offices section of [ni.com/niglobal](http://ni.com/niglobal) to access the branch office Web sites, which provide up-to-date contact information, support phone numbers, email addresses, and current events.

# Glossary

---

Symbol	Prefix	Value
p	pico	$10^{-12}$
n	nano	$10^{-9}$
$\mu$	micro	$10^{-6}$
m	milli	$10^{-3}$
k	kilo	$10^3$
M	mega	$10^6$
G	giga	$10^9$
T	tera	$10^{12}$

## Numbers/Symbols

°	degrees
/	per
%	percent
±	plus or minus
+5 V	+5 VDC source signal
+3.3 V	+3.3 VDC source signal
+12 V	+12 VDC source signal
-12 V	-12 VDC source signal

## A

A	amperes
AC	alternating current



API application programming interface

## B

backplane An assembly, typically a printed circuit board, with connectors and signal paths that bus the connector pins.

## C

C Celsius

CFR Code of Federal Regulations

cm Centimeters

COM A common terminal of the relay that either connects to NO or NC.  
*See also* [NO](#) or [NC](#).

CompactPCI An adaptation of the Peripheral Component Interconnect (PCI) Specification 2.1 or later for industrial and/or embedded applications requiring a more robust mechanical form factor than desktop PCI. It uses industry standard mechanical components and high-performance connector technologies to provide an optimized system intended for rugged applications. It is electrically compatible with the PCI Specification, which enables low-cost PCI components to be utilized in a mechanical form factor suited for rugged environments.

CSA Canadian Standards Association

## D

DC direct current

DoC Declaration of Conformity

driver Software that communicates commands to control a specific board.

**E**

electromechanical relay      Electromechanical relay made of a coil, an armature mechanism, and electrical contacts. When the coil is energized, the induced magnetic field moves the armature that opens or closes the contacts.

EMC      Electromagnetic Compatibility

**F**

FCC      Federal Communications Commission

filler panel      A blank module front panel used to fill empty slots in the chassis.

FPGA      Field Programmable Gate Array

fuse      A circuit protection device that prevents overcurrent draw.  
*See also [self-resetting fuse](#).*

**G**

g      (1) grams; (2) a measure of acceleration equal to  $9.8 \text{ m/s}^2$

$g_{\text{RMS}}$       A measure of random vibration; the root mean square of acceleration levels in a random vibration test profile.

**H**

Hz      Hertz; cycles per second

**I**

IEC      International Electrotechnical Commission—An organization that sets international electrical and electronics standards.

IEEE      Institute of Electrical and Electronics Engineers

in.      inches

## L

LED Light-Emitting Diode

## M

m meters

MAX Measurement & Automation Explorer—A controlled, centralized configuration environment that allows you to configure all of your NI devices.

ms milliseconds

## N

NI National Instruments

NO The normally-open terminal of a relay that connects to the common (COM) terminal only when the relay coil is energized.

NC The normally-closed terminal of a relay that connects to the common (COM) terminal only when the relay coil is de-energized.

## O

oz ounces

## P

PCI Peripheral Component Interconnect—A high-performance expansion bus architecture originally developed by Intel to replace ISA and EISA. It offers a theoretical maximum transfer rate of 132 MB/s.

PXI PCI eXtensions for Instrumentation

**R**

RMS	Root Mean Square
RPM	revolutions per minute—units for velocity

**S**

s	seconds
self-resetting fuse	A fuse that acts as an open circuit only when current is overdrawn. Once the overdraw ends the fuse returns to normal closed circuit operation.
system controller	A module configured for installation in slot 1 of a PXI chassis. This device is unique in the PXI system in that it performs the system controller functions, including clock sourcing and arbitration for data transfers across the backplane. Installing such a device into any other slot can damage the device, the PXI backplane, or both.

**U**

UL	Underwriter's Laboratories
----	----------------------------

**V**

V	volts
---	-------

**W**

W	watts
---	-------

# Index

---

## A

- about the NI PXI-8250, 1-1
- accuracy, monitoring, A-2
- additional monitoring features, 3-4
- alert limits, monitoring, A-2
- alert relay
  - pins, 3-7
  - specifications, A-2
- architecture, system monitoring, 3-3

## C

- calibration certificate (NI resources), B-2
- configuration and installation, 2-1
  - NI PXI-8250, 2-5
- connector
  - front panel, 3-5
  - specifications, A-2
- conventions used in the manual, *vii*

## D

- Declaration of Conformity (NI resources), B-2
- diagnostic tools (NI resources), B-1
- documentation
  - conventions used in manual, *vii*
  - NI resources, B-1
  - related documentation, *viii*
- drivers (NI resources), B-1

## E

- environmental specifications, A-2
- examples (NI resources), B-1

## F

- fan monitoring, 3-4
- features of the NI PXI-8250, 1-1
- front panel connector, 3-5
  - alert relay pins, 3-7
  - power output pins, 3-7
- front panel LEDs, 3-4
  - system status, 3-5
  - user, 3-5
- fused power output specifications, A-1

## G

- getting started with the NI PXI-8250, 1-1

## H

- hardware
  - installation, 2-1
  - introduction, 1-1
  - overview, 3-1
  - specifications, A-1
- help, technical support, B-1

## I

- information, safety, 1-2
- installing
  - hardware, 2-1
  - software, 2-1
- instrument drivers (NI resources), B-1

## K

- KnowledgeBase, B-1

## L

### LEDs

- front panel, 3-4
- system status, 3-5
- user, 3-5

## M

### maximum power requirements

- with power outputs, A-1
- without power outputs, A-1

### monitoring

- accuracy specifications, A-2
- alert limit specifications, A-2
- fan, 3-4
- temperature, 3-3
- voltage rail level, 3-3

## N

### National Instruments support and services, B-1

### NI PXI-8250

- about, 1-1
- configuration, 2-5
- features, 1-1
- getting started, 1-2
- introduction, 1-1
- software, 1-2

### NI support and services, B-1

### NI System Monitor software, 1-2

## O

### operating environment specifications, A-3

### overview

- front panel connector, 3-5
- front panel LEDs, 3-4
- hardware, 3-1

## P

### physical specifications, A-2

### pins

- alert relay, 3-7
- power output, 3-7

### power output pins, 3-7

### programming

- API, 1-2
- examples (NI resources), B-1

## R

### related documentation, *viii*

### requirements, maximum power

- with power outputs, A-1
- without power outputs, A-1

## S

### safety

- information, 1-2
- specifications, A-4

### shock and vibration specifications, A-3

### software

- installation, 2-1
- NI resources, B-1

### specifications, A-1

- alert relay, A-2
- connectors, A-2
- environmental, A-2
  - operating environment, A-3
  - storage environment, A-3

### fused power output, A-1

### maximum power (with power outputs), A-1

### maximum power (without power outputs), A-1

### monitoring accuracy, A-2

### monitoring alert limits, A-2

### physical, A-2

### shock and vibration, A-3

support, technical, B-1

system

    monitoring, 3-3

    status LEDs, 3-5

## **T**

technical support, B-1

temperature monitoring, 3-3

training and certification (NI resources), B-1

troubleshooting (NI resources), B-1

## **U**

user LEDs, 3-5

## **V**

vibration specifications, A-3

voltage rail level monitoring, 3-3

## **W**

Web resources, B-1